



VersaMax Product Details (Pressalit 4000/4100)

Features: Adjustable height, folding, wall-mounted changing table.

Designed specifically for public restrooms.

Available with manual or electric folding mechanism.

Tamper/vandal resistant. No removable parts.

Dimensions: Table: 32" wide x 72" long

Projection from wall:

Manual Fold:

Folded: 11"

Unfolded: 39.25"

Electric Fold:

Folded: 14" (Note: Folded position is slightly angled to accommodate actuator. [See image.](#))

Unfolded: 39.25"

Adjusts from 12" to 39.5"

Manual Fold:

SKU: R8594572000

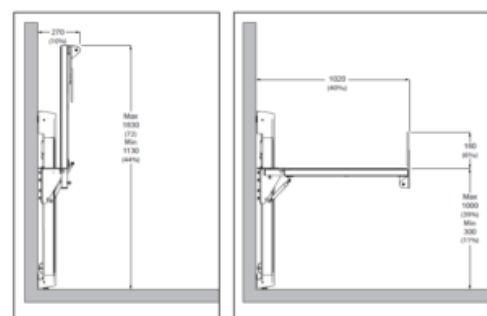
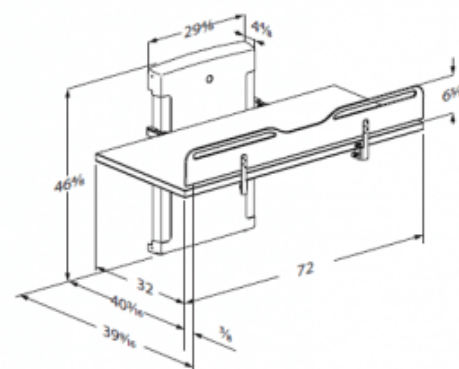

(Click image to enlarge.)

Installation Drawings:

[VersaMax Changing Table —](#)

EAN: 5708590358154

Previous version: R8594

Electric Fold:

SKU: R8595572000

EAN: 5708590356952

Previous version: R8595

Electric Fold with Wall Control:

SKU: R8595572000 / R8489

EAN: 5708590356952

Previous version: R8595 / R8489

Construction: Powder lacquered stainless steel.
Plastics (PVC, Polystyrene).
Compact laminate (Two Decorative High Pressure Laminate (HPL), "MAX Compact" Interior, Type CGS plates (0.24"/6mm) glued to steel frame. Total height (plate/frame): 2.05'/52mm)
Designed for easy clean-up.
Stain resistant construction.
Tamper/vandal resistant:

- No removable parts.
- No exposed cables.
- Secure fittings.
- Integrated controls.

Includes side rail, safety belt, wired hand control.

Installation: Retrofit friendly.
Anchors to wood blocking, masonry or concrete.
Mounting hardware included.

Electrical: Integrated transformer and US 8' power cord included.

[Electric Fold](#)

[VersaMax Changing Table — Electric Fold with Wall Control Box](#)

[VersaMax Changing Table — Manual Fold](#)

[Wall Reinforcement Guide](#)

Use a licensed contractor or plumber to install the product to avoid personal injury or property damage.

[Installation Demonstration \(Video\)](#)

[CAD Drawing — Electric Fold Model](#)

[CAD Drawing — Manual Fold Model](#)

[VersaMax Changing Table User Guide](#)

[How-To Infographic](#)

(Laminated version available on request)

Submittal Info
Spec Sheet
(pdf)

Linak liquid tight actuator and control system.

Maintenance free motor.

24v/1amp via 120 GFI wall outlet

110 Volt and 3,9 Amp gives 390 Watts

Effect(P) = Volt (U) x Ampere (I)

390 VA (Watt) = 110 V X 3,9 A

390 Watt which is the maximum effect; power consumption is approximately 0 when not in use.

Noise level: 48 decibel. Whisper quiet.

All components, including hand control, are sealed, waterproof, and UL listed.



Find architectural resources

**Adjustment
Controls:**

Height adjustment with embedded tabletop control or wired hand remote.

Wall-mounted control included with electric-fold models; optional with manual-fold.

Electric fold adjustment via wired or wall-mount controls.

**Safety Side
Rail:**

Folds up or down.

Easy one-handed operation.

Stores and locks under the table.

Flexible vinyl wraps comfortably but securely.

Plastic buckle — no metal parts against bare skin.

All components are smooth and easy to clean.

**Weight
Capacity:**

Maximum user weight (MUM): 441 lbs.

Maximum load (SWL): 452 lbs. (User weight + accessories)

When the table is loaded with 452 lbs, each mounting bolt supports 75 lbs.

This product has been tested statically with a load of 1100 lbs as the IEC 60601-1 standard requires testing with a safety factor 2.5.

Product 166 lbs (R8594: Manual folding mechanism)

Weight: 187 lbs (R8595: Electric folding mechanism)

Availability: Sold throughout the United States

Delivery: 1-2 weeks

Discount: Product price and shipping discount when purchasing multiple units.
Call for details. 800.577.1555

Warranty: Five years limited warranty on parts; one year on labor.

[See our complete warranty and other policies here.](#)

Subject to change. Last updated May 2023.

Access Your World

MAX-Ability offers complete restroom solutions that provide comfort, safety, and dignity to wheelchair users and caregivers, including ergonomic adjustable changing tables, sinks, toilets, and shower seats for total accommodation for everyone. Call us today and access your world!

1.800.577.1555



Customer Service

Purchasing & Payment Methods

[Delivery / Returns / Warranty](#)

[Privacy Policy](#)

[Terms and Conditions](#)

Resources

[Product Manuals](#)

[Installation Drawings](#)

[Internet Resources](#)

[Architects Resources \(inc. Specs/CAD\)](#)

Connect with us



All rights reserved. Copyright 2023 © **MAX-Ability, Inc.**

MAX-Ability provides special needs equipment to consumers and businesses in the USA and Canada